

FEATURES

- Digital simulation in real time
- Electrodynamical transducer (woofer, tweeter + enclosure)
- Arbitrary input (music, test signals)
- Simulates radiated sound in far field
- Additional linear band to simulate 2 channel system
- Simulates Transducer states permanently
- Measures distortion components on-line
- Adjustable signal distortion
- Blind or open A/B-comparison
- Investigates nonlinear behavior
- Allows non-destructive testing
- Explores effect of each nonlinearity
- Finds dominant source of distortion
- Assess sound quality
- Shows optimal performance/cost ratio
- Saves time and cost in prototyping
- Substitutes time-consuming listening tests
- Training of listeners

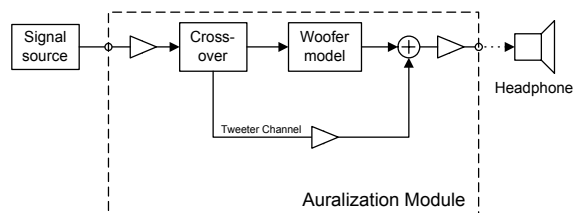

The module "Speaker Auralization" simulates the acoustic output of a loudspeaker (woofer, tweeter, system) in the far field on the basis of the identified large-signal model processed by the Distortion Analyzer 1 in real time. Before processing any external input signal supplied to terminal IN1 the linear, nonlinear and thermal parameters of the loudspeaker are imported from the module "Large Signal Identification". An additional linear channel can be activated via a crossover system to transfer an audio signal with full band-width. The nonlinear and thermal effects of the transducer are represented by the states (displacement $x(t)$, current $I(t)$, temperature $T_v(t)$, etc.) and parameter variations ($R_e(t)$, $Q_{es}(t)$) recorded in the history file. The data are stored in a data base and allows visualization and interpretation. The dynamic generation of a DC-part in the displacement, amplitude compression and jumping effects can be investigated in detail. The identified model allows to measure the nonlinear distortion d_{Bl} , d_C , $d_{L(x)}$, $d_{L(I)}$ separated according to the generating nonlinearity (force factor, compliance and inductance). In the simulated sound pressure signal $p(t)$ the linear component $p_{lin}(t)$ and each nonlinear component $p_{Bl(x)}$, $p_{L(x)}$, $p_{C(x)}$, $p_{L(I)}$ can be attenuated separately to modify the transfer response of the woofer and to investigate the impact on the subjective listening impression. Systematic listening tests can be performed by using the blind A/B switch.

Article Number: 1000-600

CONTENTS:

Large Signal Modeling of the Transducer	3
Auralization Technique	3
Assessing Large Signal Performance Objectively	5
Performing Subjective Listening Tests	7
Input Parameters	8

updated 14 August 2007



S5

Auralization

Measurement Results..... 9

Large Signal Modeling of the Transducer

Principle The transducers considered here have a moving-coil assembly performing an electro-dynamical conversion of the electrical quantities (current and voltage) into mechanical quantities (velocity and force) and vice versa.

Equivalent Circuit

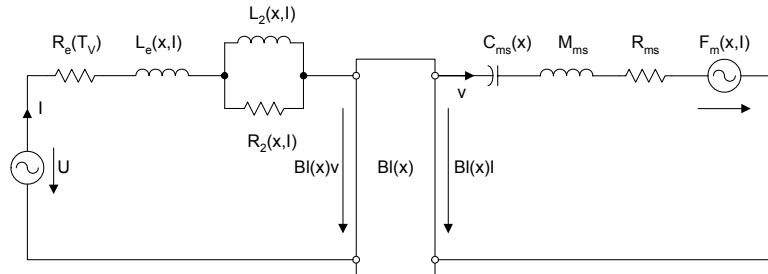

The lumped-parameter model shown above is used to describe the large signal behavior of electro-dynamical drivers at high amplitudes. In contrast to the well known linear model the elements

- electro-dynamical force factor $BI(x)$
 - compliance of mechanical suspension $C_{ms}(x)$
 - voice coil inductance represented by $L_e(x, I)$, $L_2(x, I)$ and $R_2(x, I)$ versus displacement x and current I
 - resistance of voice coil at DC represented by $R_e(T_v)$
- are not constant parameters but depend rather on one or more speaker states (displacement x , voice coil temperature T_v).

Auralization Technique

Principle In order to synthesize the loudspeaker output for any input signal in real time the set of nonlinear differential equations is transformed into the digital domain and implemented in a digital signal processor. Generating an identical copy of the driver in the digital domain makes it possible to check validity of the physical modeling, the nonlinear parameter measurement and the numerical calculations. Moreover the digital modeling allows to modify the nonlinear transfer response of the driver virtually in order to investigate the effect of each nonlinearity separately.

Digital Transducer Model

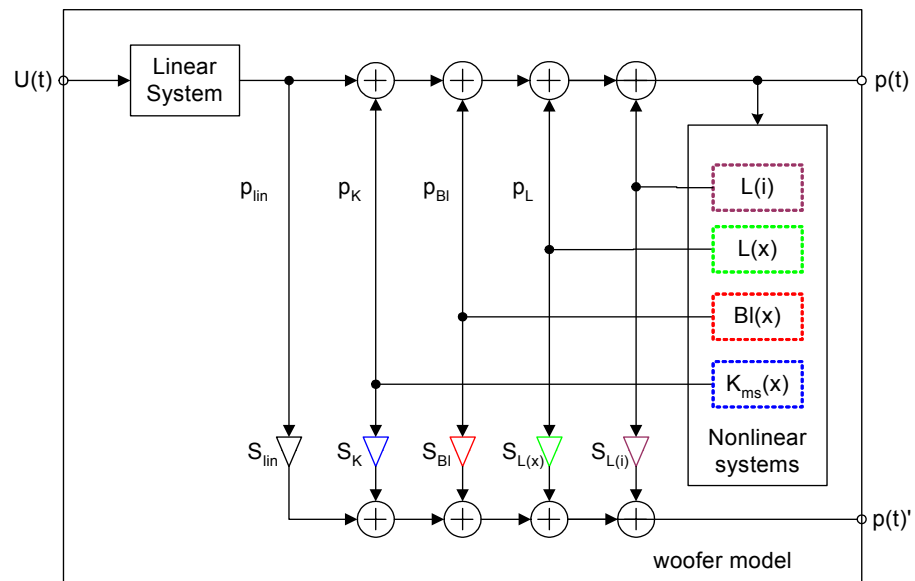

	<p>In contrast to the simulation the auralization does not modify the nonlinearities of the driver but only investigates their effects in the output signal. Thus the nonlinear differential equation and the parameters of the particular driver are kept unchanged during auralization. The digital model produces internal state variables (displacement, velocity, temperature), the distortion and the radiated sound pressure signal $p(t)$ in the far field of the driver. The sound pressure $p(t)$ is the sum of a undistorted output $p_{lin}(t)$ and the distortion components $p_k(t)$, $p_{BL}(t)$, $p_{L(x)}(t)$ and $p_{L(i)}(t)$. The undistorted output is linearly related to the drivers input $U(t)$ and the distortion components $p_k(t)$, $p_{BL}(t)$, $p_{L(x)}(t)$ and $p_{L(i)}(t)$ are generated by nonlinear subsystems representing the nonlinear stiffness $K_{ms}(x)$, $Bl(x)$, inductance $L(x)$ and $L(i)$, respectively. The nonlinear subsystems are provided with the output $p_{lin}(t)$ forming a feedback loop, where the generated distortion components react to the state variables and their own generation process. This feedback loop causes the complicated behavior of the nonlinear system at large signals (compression, jumping effects).</p>
<p>Tapping State Variables</p>	<p>In the Auralization the summing point in the feedback loop is copied by tapping the linear signal $p_{lin}(t)$ and the nonlinear distortion $p_k(t)$, $p_{BL}(t)$, $p_L(t)$. Scaling them by the attenuators S_{lin}, S_K, S_{Bl}, S_L and summing up the components will produce the auralization output $p(t)$. Changing the gain of the attenuators any desired ratio between the distortion components and the linear signal can be realized in order to determine the audibility of the distortion in listening tests. Clearly, setting all gain controllers equal one will yield the real driver output.</p>
<p>Minimal Setup</p>	<p>The minimal components required for the Auralization:</p> <ul style="list-style-type: none"> • Distortion Analyzer 1 • Signal source (CD-player, signal generator) • Reproduction system (headphone or high-quality loudspeaker speaker) • Auralization module running on the PC • Large Signal Identification module (LSI Pro) for determining the nonlinear speaker parameters.
<p>Import Driver Parameter</p>	<p>The linear, nonlinear or thermal parameters of the driver under test are imported from the Large Signal Identification (LSI-Pro) software module via the clipboard.</p>

Assessing Large Signal Performance Objectively

Any signal provided from an audio source or a generator may be used as input for the Auralization. The digital model allows access to the instantaneous state variables (sound pressure output, displacement, current, distortion). Statistical methods are applied to properties of the time signals such as peak values, RMS values and the probability density function (pdf). All of the data are stored in a history file and may be viewed versus time.

Displacement

The voice coil displacement is represented by the negative and positive peak values x_{bottom} and x_{peak} and the DC-displacement generated by driver asymmetries versus measurement time.

Voice Coil Displacement

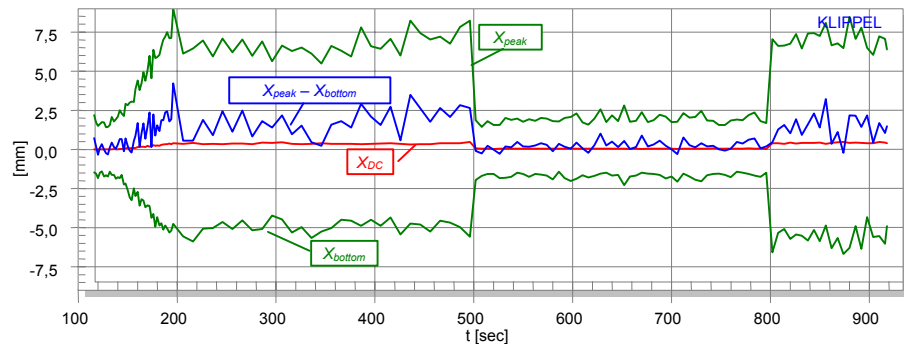

The probability density function pdf(x) shows the distribution of the displacement accumulated during the auralization session. The asymmetry of the curve is caused by a DC-component generated dynamically.

Displacement PDF (X) Histogram

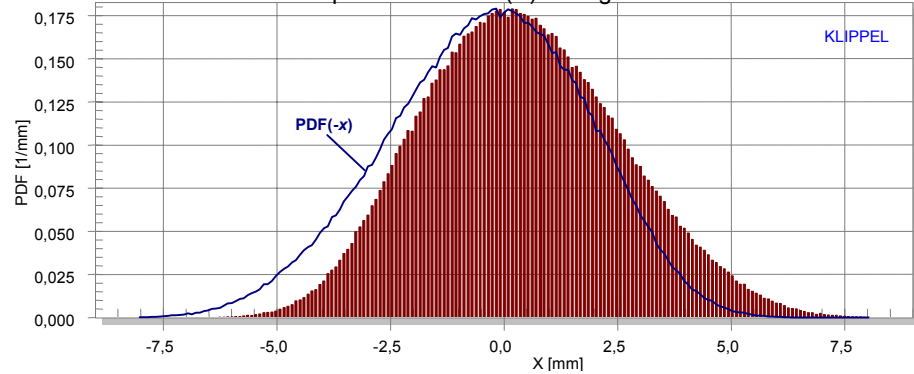

Voice Coil Temperature

The instantaneous voice coil temperature T_v is predicted on the basis of the measured thermal resistance R_{tv} and the capacity C_{tv} of the coil and the input power P .

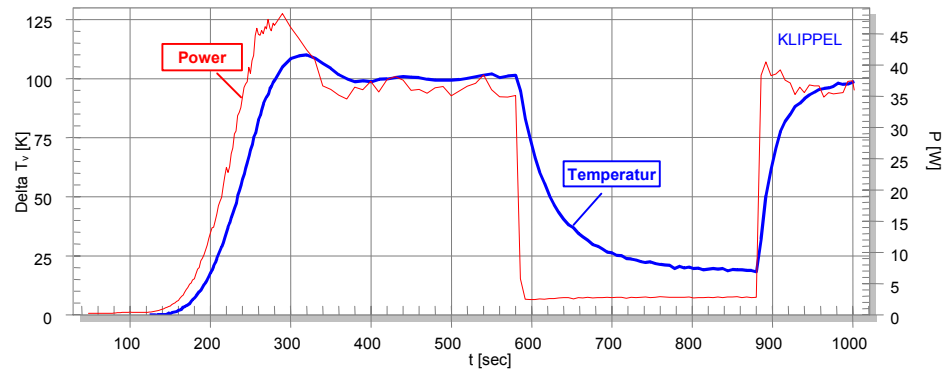

Distortions

The auralization technique makes it not only possible to adjust the magnitude of the distortion output but also to measure the magnitude of the distortion components on-line while reproducing an audio signal. Setting the peak value of each distortion signal $p_K(t)$, $p_{BI}(t)$ and $p_L(t)$ in ratio to the peak value of the total output signal p_{lin} results in an appropriate measure d_C , d_{BI} , and d_L for the contamination of the reproduced signal by $C_{ms}(x)$, $BI(x)$ and $L_e(x)$ nonlinearity, respectively.

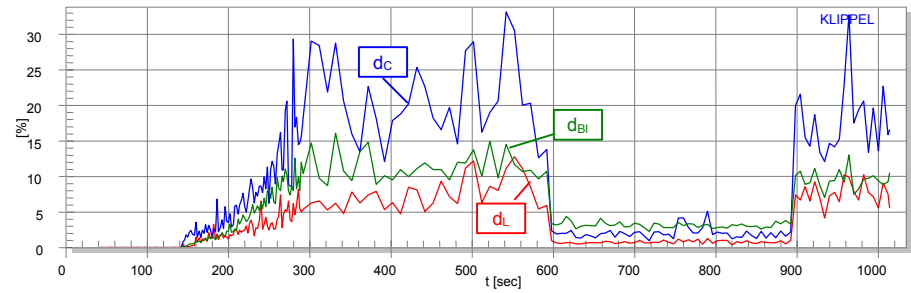

Performing Subjective Listening Tests

Input Signal The Auralization technique may be applied to any input signal (natural audio signal or a synthetically generated test signal).

Reproduction System A high-quality loudspeaker system or headphone is required for the reproduction of the Auralization output. The linear amplitude response should be sufficiently constant in the interested frequency range. The reproduction system should be operated far below the maximal limits to keep the distortion low.

Tweeter Channel If the driver under test is intended for a woofer or subwoofer channel an additional tweeter path can be realized by using a crossover. The input signal is attenuated by the gain controller S_{in} to produce displacement x_{peak} that is typical for the application of the driver. The gain controller S_{out} applied to the output signal controls the volume of the sound at the headphone. The gain controller $S_{tweeter}$ may be used for attenuating the gain of the tweeter channel.

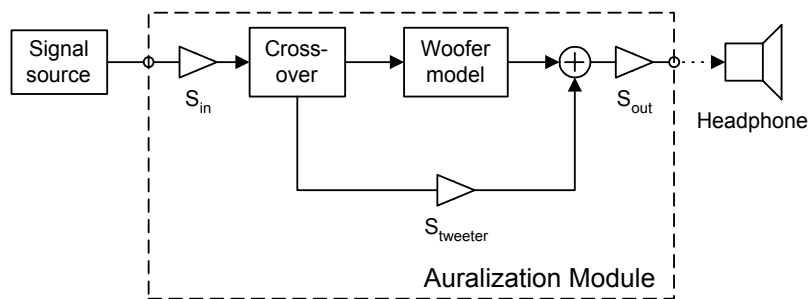

Open Test

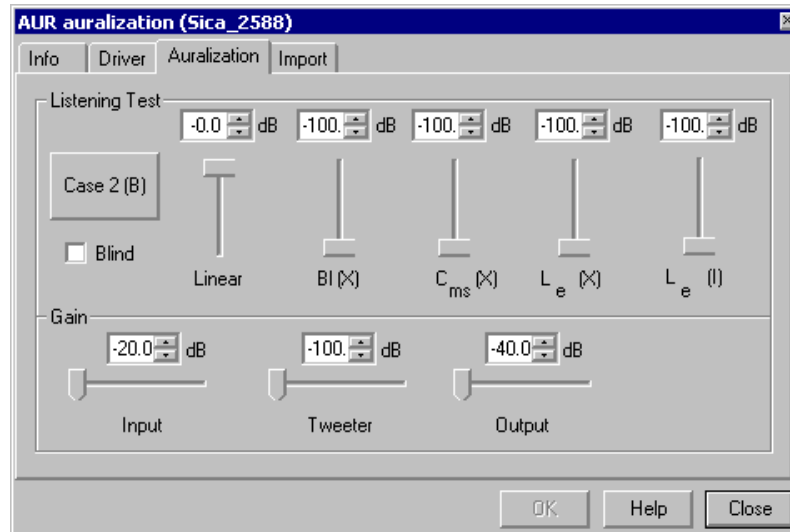

In the open test mode the user has access to all attenuators to change the amplitude of the linear and distortion components, the tweeter, the input and output signal. The simple intuitive user interface makes it easy to become familiar with the auralization technique. This mode is optimal for initial training of the listeners and to select a music program used as a critical or representative stimulus in systematic listening test.

Training Before starting with listening tests the subject may listen to the pure distortion components by attenuating the linear component ($S_{lin}=0$) and all nonlinear components besides one. Since each distortion component has characteristic properties the listener may detect speaker distortion much more precisely after a short training session.

AB-Comparison The user may switch between two settings of the attenuators to perform a direct AB-comparison between two cases (Case 1 and Case 2). Normally one case represent the virtual linear driver ($S_{lin}=1, S_B=0, S_K=0, S_{L(x)}=0, S_{L(l)}=0$) and the second case represents the real driver considering all distortions ($S_{lin}=1, S_B=1, S_K=1, S_{L(x)}=1,$

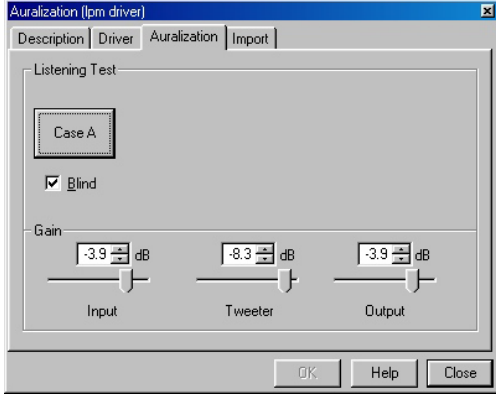
$S_{L(i)}=1$.	
<p>Blind Test</p> 	<p>These tests may be performed as blind or even double blind tests to avoid any bias and to check the reproducibility of the results. During the blind test the user has no access to the attenuator for the linear signal and the distortion but may adjust the input, output and tweeter amplitude. The designation Case 1 and Case 2 will be renamed by chance to Case A and Case B in order to hide the setup to the subject. The amplitudes of all state variables and distortion components are monitored during the blind test and stored in the history file. The setup may be viewed after the test</p>
to determine thresholds of audibility.	
<p>Measurements Below Threshold</p>	<p>Using an uncritical stimulus (e.g. not enough bass) in the auralization of a high-quality driver the distortion might be inaudible for some listeners. To determine the threshold of audibility in this case the amplitude of the linear signal may be attenuated ($S_{lin} = -6$ dB) to enhance the nonlinear distortion in the reproduced output. This enhancement may be interpreted as an additional headroom in the detection of the distortion. Trained listeners are much more sensitive to the distortion and will give the loudspeaker less headroom than inexperienced subjects.</p>
<p>Communication</p>	<p>The Auralization provides a common basis for communication between engineers and non-technical listeners. Subjective sensations are coupled with objective parameters. The audibility thresholds may be used as target values for design and assessment of a particular driver. The physical state variables (maximal displacement, input power, voice coil temperature) monitored during the listening tests show the conditions for the generation of signal distortion and the relationship between effects and physical causes (nonlinearities).</p>
<p>Listening Example</p>	<p>A practical demo of the auralization technique applied to artificial test signals and a representative music example may be found on the website http://www.klippel.de/service/aural/auralization.htm.</p>

Input Parameters					
Parameter	Symbol	Min	Typ	Max	Unit
Speaker Modeling					
The complete nonlinear speaker parameter set must be imported from the Large Signal Identification module.					
Attenuation linear signal	S_{lin}	-100		0	dB
Attenuation force factor distortion	S_{Bl}	-100		0	dB
Attenuation suspension distortion	S_C	-100		0	dB
Attenuation inductance distortion	$S_{L(x)}$	-100		0	dB
Attenuation flux modulation	$S_{L(i)}$	-100		0	dB
Switch for AB comparison		case 1 and 2 (in blind test A and B)			
Mode switch		open		blind	
Loudspeaker System Modeling					
Attenuation external input signal	S_{in}	-20		0	dB
Attenuation output signal	S_{out}	-20		0	dB
Attenuation tweeter band	$S_{tweeter}$	-100		0	dB

Measurement Results

Time Varying Parameters

	Electrical voice coil resistance	$R_e(t)$
	Electrical loss factor	$Q_{es}(x=0, t)$
	Total loss factor	$Q_t(x=0, T_V)$

Transducer State Variables

	Peak value terminal voltage	$U_{peak}(t)$
	RMS value terminal voltage	$U_{rms}(t)$
	Probability density function voltage	$pdf(u)$
	Peak value input current	$I_{peak}(t)$
	RMS value input current	$I_{rms}(t)$
	Real input power	$P(t)$
	Peak value displacement	$x_{peak}(t)$
	Bottom value displacement	$x_{bottom}(t)$
	DC component displacement	$x_{DC}(t)$
	Probability density function displacement	$Pdf(x)$
	Voice coil temperature	$\Delta T_V(t)$

Distortion of the woofer

	Force factor distortion	$d_{Bf}(t)$
	Compliance distortion	$d_C(t)$
	Inductance distortion (L(x) versus displacement x)	$d_{L(x)}(t)$
	Flux modulation (L(i) versus current i)	$d_{L(i)}(t)$

Nonlinear Parameters

The nonlinear parameter setup imported from Large Signal Identification may be viewed in detail.

LIMITS

Parameter	Symbol	Min	Typ	Max	Unit
Woofer					
Transducer Parameters	must be imported from module "Large Signal Identification (LSI)"; special requirements for transducers are specified in this module.				
Audio Signal					
Input Voltage (peak)	U_{in}	-10		10	V
Input Impedance	R_{in}		10		k Ω
Output Voltage (peak)	U_{out}	-9		9	V
Output Impedance	R_{out}		600		Ω
Crossover frequency	f_{cross}		1,5		kHz
Cut-off frequency highpass woofer	f_{low}		4		Hz
Cut-off frequency lowpass tweeter	f_{high}		24		kHz

Find explanations for symbols at <http://www.docs.klippel.de/symbols.pdf>

updated 14 August 2007



Klippel GmbH
Mendelssohnallee 30
01309 Dresden, Germany

www.klippel.de
info@klippel.de

TEL: +49-351-251 35 35
FAX: +49-351-251 34 31