

FEATURES

- Identifies linear transducer model
- Measures suspension creep
- LS-fitting in impedance
- LS-fitting in displacement (optional)
- Single-step measurement with laser sensor
- Two-step measurement with additional mass or test enclosure
- Logarithmically spaced multi-tone excitation
- Measurements at low and high amplitudes
- Monitors ratio signal to noise + distortion (SNR+D) and noise floor
- Automatic validity check
- High reliability and reproducibility
- Fast measurements

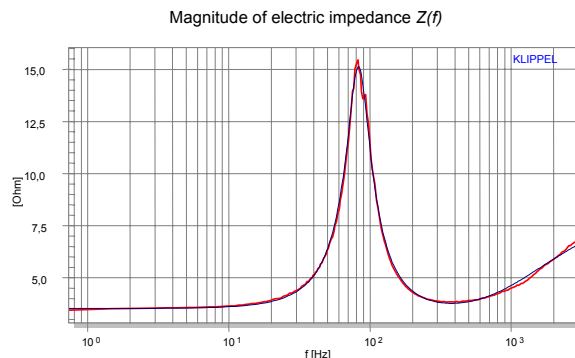

This module identifies the electrical and mechanical parameters of electro-dynamical transducers by measuring the voltage and current at the speaker terminals. Using an optional laser displacement sensor the identification dispenses with a second measurement and avoids problems due to leakage of the test enclosure and mass attachment. This kind of measurement also identifies the parameters of the suspension creep giving more accuracy of the loudspeaker model at low frequencies.

The measurement indicates insufficient signal to noise ratio and malfunction operation due to nonlinear effects of the driver or amplifier limiting.

Article Number: 1000-400

CONTENTS:

Linear Modeling of the Transducer.....	2
Measurement Technique.....	3
Ensuring Validity of the Results.....	4
Import Parameter.....	5
Measurement Results.....	5

Linear Modeling of the Transducer

Principle

The transducers considered here have a moving-coil assembly performing an electro-dynamical conversion of the electrical quantities (current and voltage) into mechanical quantities (velocity and force) and vice versa.

Equivalent Circuit

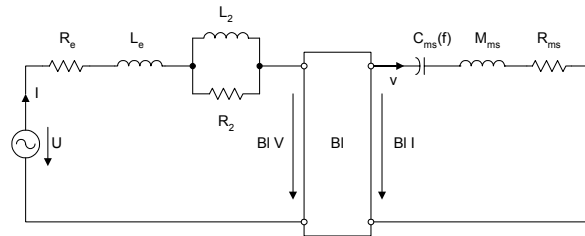

The lumped-parameter model shown above is valid at low frequencies where the geometrical dimensions of the transducer are small in comparison to the wave length. In this case the mechanical system may be represented by a moving mass M_{ms} , a compliance $C_{ms}(f)$ and a mechanical resistance R_{ms} . The force factor BI couples the mechanical with the electrical side of the transducer. The electrical impedance is modeled by the electrical resistance R_e and additional elements L_e , L_2 and R_2 that describe the para-inductance and losses due to eddy currents. It is also assumed that the amplitude of all state variables is sufficiently low to neglect parameter variations caused by thermal and nonlinear mechanisms.

Suspension Creep

After applying a constant force to a loudspeaker suspensions the voice coil displacement slowly varies and will find the equilibrium after a few seconds (creep). This effect also affects the dynamic behavior and is visible in the transfer function $H_x(f)$ between voltage $U(f)$ and displacement $X(f)$ as shown below.

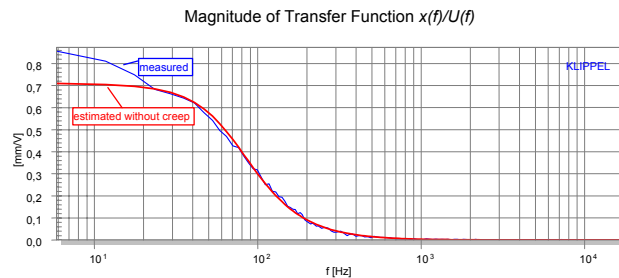

Below the resonance frequency f_s there is a significant difference between the magnitude of the measured response of $H_x(f)$ and the predicted response using the traditional model.

To consider the creep effect the constant parameter compliance C_{ms} is replaced by the dynamic transfer function [1]:

$$C_{ms}(f) = C_{ms} \left[1 - \lambda \log_{10} \left(\frac{f}{f_s} \right) \right]$$

where C_{ms} is the linear compliance and f_s is the driver resonance frequency. There is a straight forward interpretation of the creep factor λ . The quantity $\lambda \cdot 100\%$ indicates the decrease of the compliance C_{ms} in percentages at low frequencies. For a frequency one decade below the resonance frequency f_s the compliance C_{ms} is decreased by $\lambda \cdot 100\%$.

[1] Knudsen, M. H. and Jensen, J. G. *Low-frequency loudspeaker models that include suspension creep*. J. Audio Eng. Soc., Vol. 41, No. 1 / 2, 1993

Operating condition

The Linear Parameter Measurement can be applied to drivers operated in free air or mounted in a sealed enclosure. An additional mass may be applied to the moving assembly of the transducer.

Measurement Technique

Principle

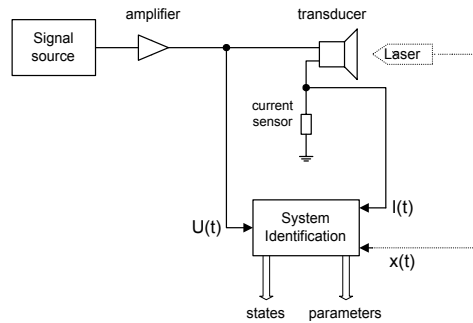

The parameters of the linear transducer model are identified by measuring the electrical voltage $U(t)$ and current $I(t)$ at the transducer terminals. The linear parameters are identified by fitting the model to the measured impedance curve over the full frequency range.

Minimal setup

- Distortion Analyzer 1
- Power amplifier
- Amplifier and speaker cable
- Computer connected via USB

Excitation Signal

The stimulus used during the measurement is a sparse multi-tone complex spaced logarithmically on frequency. This signal is optimal for the parameter identification at small amplitudes because the transducer is only excited at frequencies of interest. The user may specify the amplitude and the frequency range covered by the tones and their distance (relative resolution). The user may specify either the voltage at the output connector OUT 1 or the voltage at the terminals of the speaker connected to output SPEAKER 1 (SPEAKER 2). In the later case the amplifier gain is determined at 750 Hz without load prior to the main measurement and the excitation level is adjusted accordingly. Also the amplifier low frequency roll off is determined and compensated for the two lowest frequency lines.

Acquisition

The state variables are acquired at sample rates up to 48 kHz. Optionally, averaging of the periodically measured time signals improves the signal to noise ratio.

Spectral Analysis

All of the measured time signals are subject of a FFT analysis. The resulting spectra show not only the fundamental response to the sparse multi-tone signal but also the distortion generated by the transducer or amplifier and residual measurement noise.

Electric Current $I(f)$

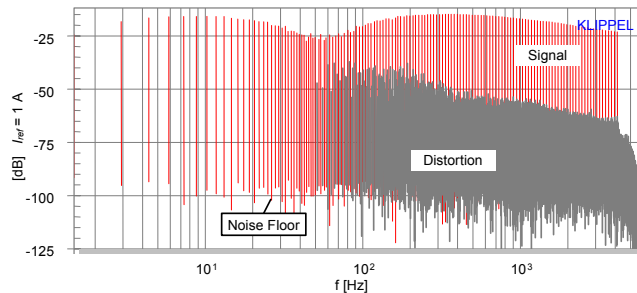

Parameter Estimation

All points of the measured impedance response are used for the identification of the electrical parameters, the resonance frequency and for the loss factors of the mechanical system. The estimated response (bold line) based on the identified model is displayed together with the measured response (thin line) to show the quality of the fitting.

Magnitude of electric impedance $Z(f)$

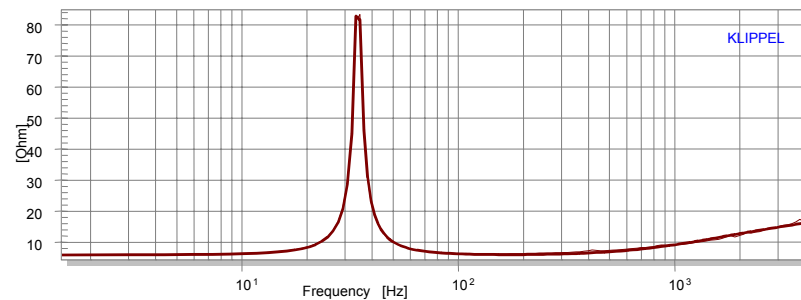

Using Added Mass or Test Enclosure

The Linear Parameter Measurement module supports the traditional two step techniques for the estimation of the mechanical parameters. They require a second (perturbed) measurement where the transducer is either mounted in a test enclosure or an additional mass is attached to it.

Optional Laser Sensor

Both perturbation techniques are time consuming and the accuracy of the results may be deteriorated by leakage of the enclosure and problems due to the attachment of the mass. There are also transducers where neither of the techniques can be applied.

An inexpensive laser sensor based on optical triangulation (see Displacement Meter of the Analyzer System) may be used to measure voice coil displacement simultaneously.

The measured transfer function $H_x(f)$ between terminal voltage $U(f)$ and displacement $x(f)$ is used to estimate the mechanical parameters. Considering the creep effect at low frequencies gives a good agreement between measured response (thin curve) and the modeled response (bold line).

Magnitude of transfer function $H_x(f)=x(f)/U(f)$

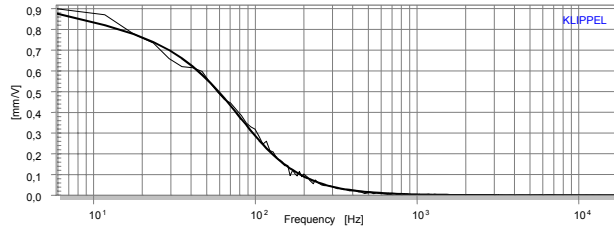

Acoustical Environment

The influence of the room acoustics on the driver parameters may be neglected for a normal room size (volume > 30 m³) and a distance of at least 1 m to the walls.

Sound Pressure Response

Optionally a microphone may be connected to the Distortion Analyzer 1 and the radiated sound pressure signal may be measured simultaneously. The sparse multi-tone complex allows to measure the speaker distortion on-line. This way a unique fingerprint of the speaker is obtained. Furthermore the driver nonlinearities can be identified directly

Spectrum $p(f)$ of microphone signal

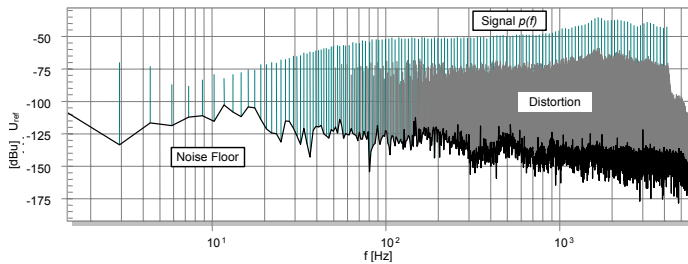

In the example above the speaker produces substantial distortion which exceed 10 % at all frequencies. This kind of distortion are produced by motor nonlinearities whereas stiffness distortion are restricted to low frequencies and inductance and Doppler distortion increase by 6 dB toward higher frequencies.

Ensuring Validity of the Results

Principle

The multi-tone complex used as excitation stimulus makes it possible to measure the fundamental components, signal distortion and the noise level simultaneously. This information is the basis for detecting a malfunction operation on-line and to give warnings if amplifier and transducer are not connected properly.

Amplifier Check

Spectrum $U(f)$ of voltage at speaker terminals

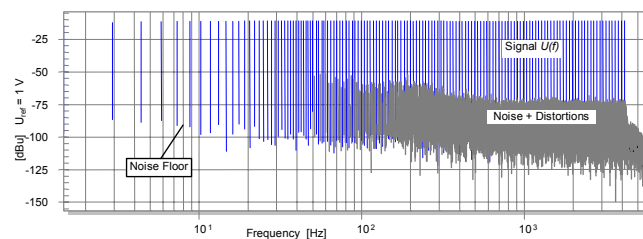

A low signal to noise ratio of the voltage signal at the terminals indicates that the gain of the amplifier is too low. A humming component (50 / 60 Hz) due to a ground loop can also be found easily.

	The signal to distortion ratio shows a malfunction operation of the amplifier (such as limiting). In the example below the distortion generated by the power amplifier are 50 dB below the fundamental components and 25 dB above noise floor.
Small Signal Domain	If the signal to noise ratio in the measured current signal is too small then the number of averaging has to be increased. If the signal to distortion ratio in the measured current signal is too small then the driver behaves nonlinear and the linear model becomes invalid.

Import Parameter					
Parameter	Symbol	Min	Typ	Max	Unit
Transducer Parameters					
Effective area of the driver diaphragm.	S_d	0.01		10000	cm ²
Voice coil resistance at DC (optional)	R_e	0.1			Ω
Force factor (optional)	Bl	0.01			N/A
Moving mass (optional)	M_{ms}	0.1			g
Identification					
Method		<ul style="list-style-type: none"> using laser displacement meter, additional mass or using test enclosure optionally a shunt can be used to improve the signal to noise ratio for drivers with a low Q_{ts} 			
Additional mass	M_{add}	1			g
Volume of sealed enclosure	V_{box}	0.5			dm ³ (l)
Shunt resistance	R_{shunt}	0	15		Ohm
Stimulus					
Highest frequency	f_{max}		2	18	kHz
Reference frequency	f_{ref}	0.19	25		Hz
Relative frequency resolution	$\Delta f/f_{ref}$	1/99	1/24	1	octave
Voltage at speaker terminals (power amplifier output voltage)		0 -200	0.3 -8.24	200 48.2	V_{rms} dBu
Voltage at OUT 1 (power amplifier input voltage)		0 -200	0.02 -31.8	6.5 19.1	V_{rms} dBu
Measurement					
Sensor terminal	Speaker 1 or Speaker 2				
Number of averaging		1	16	128	

Measurement Results		
Parameter	Symbol	Unit
DC resistance of driver voice coil	R_e	Ω
Lumped elements of para-inductance	L_e	mH
	R_2	Ω
	L_2	mH
Electrical resistance due to mechanical losses	R_{es}	Ω
Electrical capacitance representing moving mass	C_{mes}	μF
Electric inductance representing driver compliance	L_{ces}	mH
Real part of voice coil impedance at f_s	$\Re\{Z_L(f_s)\}$	Ω
Mechanical mass of driver diaphragm assembly including air load and voice coil	M_{ms}	g
Mechanical resistance due to mechanical losses	R_{ms}	kg/s
Mechanical compliance of driver suspension	C_{ms}	mm/N
Creep factor	λ	
Mechanical stiffness of driver suspension	K_{ms}	N/mm

Force factor at the rest position (B/l product)	B/l	N/A
Derived Parameters		
Resonance frequency of driver	f_s	Hz
Total Q-factor of driver considering R_e and R_{ms} only	Q_{ts}	
Electrical Q-factor of driver in free air considering R_e only	Q_{es}	
Electrical Q-factor considering $\Re\{Z_L(f_s)\}$	Q_{eps}	
Total Q-factor considering all losses ($R_e, R_{ms}, \Re\{Z_L(f_s)\}$)	Q_{tp}	
Mechanical Q-factor of driver in free air considering R_{ms} only	Q_{ms}	
Reference efficiency of electro-acoustical conversion (2π -radiation load)	η_0	%
Characteristic sound pressure level	L_m	dB
Equivalent air volume of suspension	V_{as}	dm ³ (l)
Resonance frequency of driver in enclosure	f_{ct}	Hz
Electrical Q-factor of driver in enclosure considering R_e only	Q_{ect}	
Resonance frequency of driver with additional mass	f_m	Hz
Time Signals		
Waveform of voltage at transducer terminals	$U(t)$	V
Waveform of current at transducer terminals	$I(t)$	A
Waveform of sound pressure	$p(t)$	Pa
Waveform of displacement	$X(t)$	mm
Spectra		
Voltage spectrum	$U(f)$	dBu
Current spectrum	$I(f)$	dB
Sound pressure spectrum	$p(f)$	dBu
Displacement spectrum	$X(f)$	mm
Measured (laser/microphone) and fitted sound pressure level at 1W / 1m	SPL	dB
Transfer Functions		
Magnitude of measured and fitted electrical impedance $Z(f)$	$Z(f) = U(f)/I(f)$	Ω
Phase of measured and fitted electrical impedance $Z(f)$	$Z(f) = U(f)/I(f)$	rad
Magnitude of measured and estimated displacement transfer function	$H_x(f) = X(f)/U(f)$	mm/V
States and Measurement Variables		
Peak to peak value of voltage at terminals	U_{pp}	V
DC part of voltage signal	U_{dc}	V
AC part of voltage signal	U_{ac}	V
Digital headroom of voltage signal	U_{head}	dB
Ratio of signal to noise + distortion in voltage signal	U_{SNR+D}	dB
Frequency of noise maximum in voltage signal	$f_{u,noise}$	Hz
Peak to peak value of current at terminals	I_{pp}	A
DC part of current signal	I_{dc}	A
AC part of current signal	I_{ac}	A
Digital headroom of current signal	I_{head}	dB
Ratio of signal to noise + distortion in current signal	I_{SNR+D}	dB
Frequency of noise maximum in current signal	$f_{i,noise}$	Hz
Peak to peak value of displacement signal	X_{pp}	mm
DC part of displacement signal	X_{dc}	mm
AC part of displacement signal	X_{ac}	mm
Digital headroom of displacement signal	X_{head}	dB
Frequency of highest valid line in displacement signal	$f_{x,cutoff}$	Hz
Peak to peak value of microphone signal	p_{pp}	V
DC part of microphone signal	p_{dc}	V
AC part of microphone signal	p_{ac}	V
Digital headroom of microphone signal	p_{head}	dB
Ratio of signal to noise + distortion in microphone signal	p_{SNR+D}	dB
Frequency of noise maximum in microphone signal	$f_{p,noise}$	Hz



updated January 17, 2008

Klippel GmbH
Mendelssohnallee 30
01309 Dresden, Germany

www.klippel.de
info@klippel.de

TEL: +49-351-251 35 35
FAX: +49-351-251 34 31